

## EFFECTS OF THRUST WASHER BEARING SURFACE CHARACTERISTICS ON PLANETARY GEAR TRAIN WEAR

E. Bergseth <sup>a\*</sup>, M. Henriksson <sup>b</sup>, P. Broukhiyan <sup>a</sup>, L. Sugutur <sup>a</sup>, U. Sellgren <sup>a</sup>, E. Nordin <sup>b</sup>

\*bergseth@kth.se

<sup>a</sup> KTH Royal Institute of Technology,  
Brinellvägen 83, Stockholm, Sweden

<sup>b</sup> Scania CV,  
Granparksvägen 10, Södertälje, Sweden

### KEYWORDS

*Thrust Washers; Planetary Gears; Wear*

### ABSTRACT

There is an ever ongoing effort to increase operating life, reduce power losses, and to ensure the overall functional performance of trucks. The main focus of the presented research is to enable development and production of extremely reliable and robust thrust washer bearings in heavy-duty truck drivetrains.

Washer wear gives frictional power losses that cause high local temperatures due to highly nonlinear thermo-mechanical effects that also possibly trigger thermo-elastic instabilities. These interaction phenomena may cause fatigue and local excessive wear with very hard particles that further damage adjacent high-performance components. A planetary gear train with spur gears was selected as a case study (Fig. 1), with washers in between the planet wheel and planet carrier. Inevitably, thrust forces occur in spur planetary gear trains, e.g. due to the design of the planet carrier which has an unsymmetrical stiffness – it is stiffer on the rear compared to the front side. This may cause a twisting torque on the carrier. This twisting torque is transferred by the planets to the needle bearings and further on to the washers. Thus, the system performance would benefit from a low-friction interface between the washer bearing surface and the planet wheel. See Jackson and Green [1] for more reasons of thrust washer failures.

Four differently surface treated washer materials were tested using a pin-on-disc tribometer. The tests were performed at 0.5 m/s and lasted for 5000 cycles at maximum Hertzian contact pressure 870 MPa, repeated three times. Three disc material tested was nitro-carburized and one was electroless nickel plated with teflon (or Nedox®), all with SS 2541 steel grade. The nitro-carburized test disc with teflon coating resulted in the lowest friction. Although the coating wears off at

an early stage, it resulted in the lowest wear of the pin specimens which here represent the planet gear. The electroless nickel plated with teflon resulted in the most stable frictional behaviour and low wear of pin and disc specimens. High wear of pin specimens were the result when using the nitro-carburized disc with ANS Tribonite™. The nitro-carburized disc with no coating resulted in very high friction. The tests were compared with long-time running gear rig tests which resulted in favour for the electroless nickel plated with teflon, here on steel grade SS 1265-11. The electroless nickel plated with teflon did not give the lowest friction in the lab scale tests, the difference in steel grade might have affected the electroless process. The overall results indicate that lab scale tests can be made to try out new washer materials.

The results from the presented research will be applicable to a range of subsystems along the powertrain, including both motor and the drivetrain.

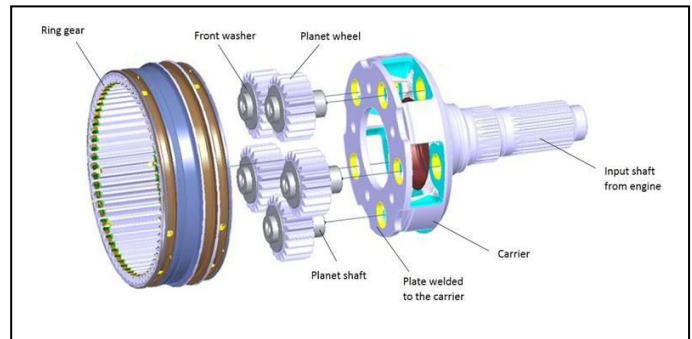

Fig.1 Exploded view of the planetary gear train.

### REFERENCES

- [1] Jackson, R. L. and Green, I., “The Thermoelastic Behavior of Thrust Washer Bearings Considering Mixed Lubrication, Asperity Contact, and Thermoviscous Effects”, Tribology Transactions, 51, 2008, 19-32.